

PRE-ENGINEERED CHEMICAL METERING SYSTEMS

Pre-Packaged & Self-Contained Chemical Feed Systems



PP-1 Single Pump System



PP-2 Dual Pump System

FEATURES

- Suitable for base or wall mounting
- Flow rates to 25 GPH, pressures to 150 PSI
- Flow Monitor provides audible & visual indication upon loss of flow
- Relay output can start back-up pump and/or signal an operator remotely via an autodialer
- Integral leak containment with optional level alarm

STANDARD EQUIPMENT

- LMI 9-Series Pump*
- Digipulse Flow Monitor
- ALM-9 Pump Monitor
- 4-Function Valve (Back pressure, Pressure Relief, Anti-Siphon, Priming Aid)
- 500ml Calibration Cylinder
- Pulsation Dampener
- Diaphragm Protected Pressure Gauge
- Foot Valve with Suction Strainer
- PVC Ball Valves

* Note: pump selection is based on application

OPTIONAL EQUIPMENT

- Auto-Prime Valve
- Auto-Dialer
- Flowmeters
- Leak Detection
- Supply Tank Level Monitoring
- Tanks
- On-Line Analyzers
- Corp Stops with Solution Tube Assembly

SPECIFICATIONS

- Panel Material: Polypropylene
- Process Piping Material: PVC
- Process Connections: 1/2" NPT
- Dimensions (PP-1): 48"H x 15"W x 14.5"D
- Dimensions (PP-2): 48"H x 30"W x 14.5"D
- Weight (PP-1): 37 Lbs. (without pump)
- Weight (PP-2): 50 Lbs. (without pumps)
- Power: 115 VAC

PP-1 Prepackaged Metering Pump System with Flow Monitoring Capabilities

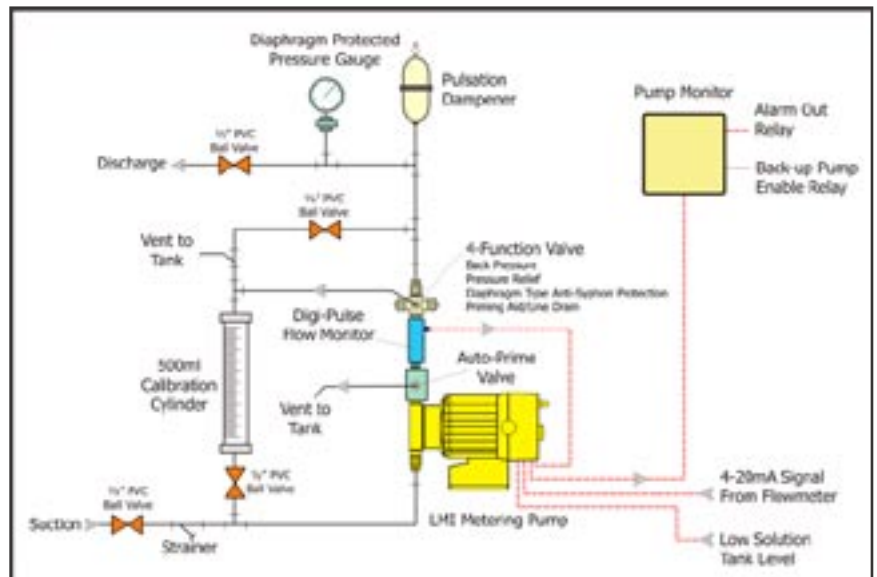

FLOMOTION SYSTEMS INC.

586 N. French Rd., Suite 6
Buffalo NY 14228-2103
Tel: 800-909-FLOW (3569)
Tel: 716-691-3941 Fax: 716-691-1253
Email: info@fломotionsystems.com
www.fломotionsystems.com